

## Microwave drying machine

### What are the advantages of Microwave drying machine?

1. The microwave drying equipment is uniformly heated and uniformly dried. Good quality and reasonable price.
2. As a professional manufacturer of microwave drying equipment, our Leader can customize microwave drying equipment for you.
3. Long use time and easy maintenance.
4. High efficiency, effort.
5. Easy to control, advanced technology, equipment ready to use, flexible and convenient operation.
6. No waste water&gas, protection of the environment without any pollution ,is a safe and harmless high-tech.

### Product Specification:

	Microwave drying machine
Microwave frequency	915±25MHz
Microwave power	10kw-200kw 以上 (Continuously adjustable)
Transmission speed	0.1~3m/min frequency conversion
Microwave leakage	≤5mw/cm2 (GB5959.6-87)
Dry Quantity	0.5~1.0T/ h
Hourly capacity	5-7t
Equipment Size:	Length × width × height 8000 × 5000 × 2300 (mm) (can be customized)
control method	Touch screen, PLC control

			
10KW Microwave drying machine	20kw Microwave drying machine	30kw Microwave drying machine	higher power microwave drying equipment Can be customized

The volumetric heating and reduced processing time make microwaves an attractive source of thermal energy. Since microwaves alone cannot complete a drying process,

it is recommended to combine techniques, such as forced air or vacuum, in order to further improve the efficiency of the microwave process.

Comparison of convective and microwave drying of grape

Drying method	Air temperature (°C)	Air flow rate (kg/s)	Drying time (h)	Specific energy consumption (MJ/kg water)
Convective	50	0.0210	23.66	90.35
	60	0.0204	16.75	81.15
Microwave	50	0.0210	5.58	21.86
	60	0.0204	3.86	19.08

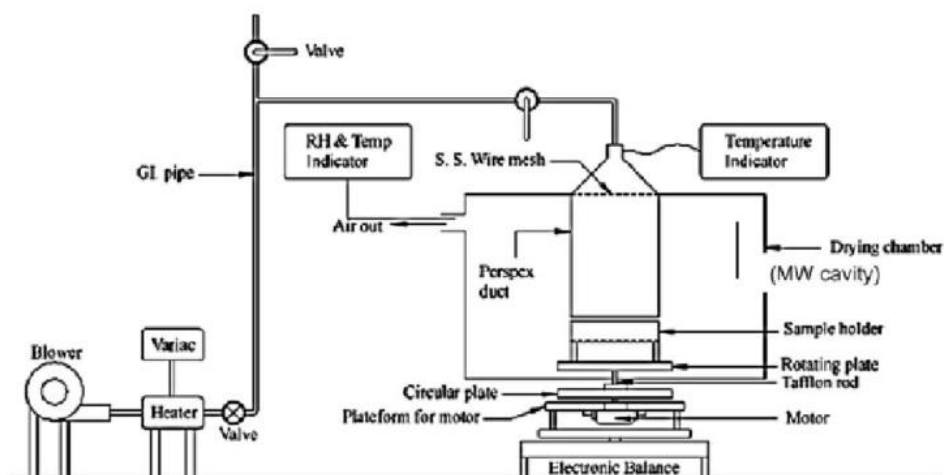
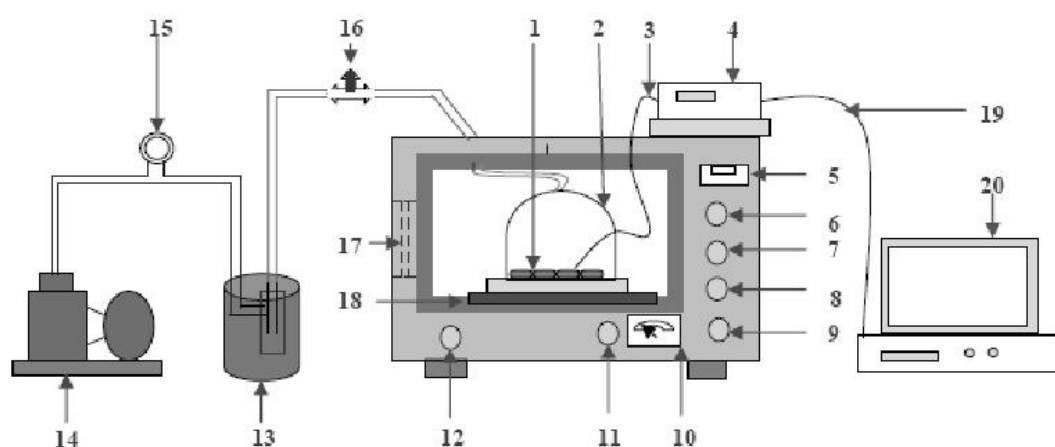

### Why choose Leader Machinery?

In addition to the reasonable price and good mechanical quality when purchasing mechanical equipment, after-sales is very important. The perfect service can bring you great convenience. In our factory, we can provide customers with: installation, worker training, maintenance and 24-hour service hotline. When you purchase our microwave drying equipment or microwave dewatering equipment, if you have any questions, please contact us and we will try our best to solve the problem.